

# **WCT900 Series Cooling Tower Controllers**

## **Part 1. General**

### **1.1 Scope**

- A.** This section describes the requirements for a multiple input/output cooling tower controller.
- B.** Under this item, the contractor shall furnish and install the cooling tower control equipment and accessories as indicated on the plans and as herein specified.

### **1.2 Submittals**

- A.** The following information shall be included in the submittal for this section:
  - 1. Data sheets and catalog literature for the cooling tower controller and sensors.
  - 2. Interconnection and dimensional drawings.
  - 3. List of spare parts

## **Part 2. Products**

### **2.1 Cooling tower controller**

- A.** The cooling tower control system shall be capable of measuring system conductivity and temperature. The conductivity sensors shall be either a contacting style or an electrodeless style. Other optional sensors up to a maximum of 8 shall be a choice of pH, ORP, ISE, PTSA, free chlorine, total chlorine, chlorine dioxide, ozone, Peracetic acid, or hydrogen peroxide. Twelve digital inputs are available for sensors that shall include a flow switch, contacting water meter, paddlewheel flowmeter, chemical feed monitor, or other dry contact devices. Optional corrosion inputs, up to a maximum of 8 shall be available. Outputs shall include eight relays, and up to a maximum of sixteen optional 4-20 mA outputs. Digital communications shall be via Ethernet. Optional BACnet and Modbus TCP shall be available. The controller shall be accessible via the Internet for configuring, data logging, and control of relay outputs. The USB port shall provide the ability to upgrade the software in the controller to the latest version, save all the set points from a controller onto a USB flash disk and import settings into another W900 controller, and download datalog files to a USB flash disk. On-screen graphing of one analog signal and one digital signal/relay state shall be available on the touchscreen display.

**B. Control Module:**

1. **Enclosure:** Polycarbonate Resin, NEMA 4X, lockable hinged door.

2. **Power:** 100-240 VAC, 50 or 60 Hz, 13 A maximum

3. **Inputs:**

*Sensor Input Signals (0, 1 or 2 depending on model code)*

Contacting Conductivity 0.01, 0.1, 1.0, or 10.0 cell constant OR

Electrodeless Conductivity OR

Disinfection OR

Amplified pH, ORP or ISE Requires a preamplified signal. Walchem WEL or WDS series recommended.

±5VDC power available for external preamps.

Each sensor input card contains a temperature input

Temperature 100 or 1000 ohm RTD, 10K or 100K Thermistor

*Analog (4-20 mA) Sensor Input (0 to 24 depending on model code)*

2-wire loop powered or self-powered transmitters supported

3 or 4 –wire transmitters supported

Two to Six channels per board, depending on model

Channel 1, 130 ohm input resistance

Channel 2-6, 280 ohm input resistance

All channels fully isolated, input and power

Available Power One independent isolated 24 VDC ± 15% supply per channel

1.5 W maximum for each channel

*Digital Input Signals (12 standard6):*

State-Type Digital Inputs

Electrical: Optically isolated and providing an electrically isolated 12 VDC power with a nominal 2.3mA current when the digital input switch is closed

Typical response time: < 2 seconds

Devices supported: Any isolated dry contact

(i.e. relay, reed switch)

Types: DI State

Low Speed Counter-Type Digital Inputs

Electrical: Optically isolated and providing an electrically isolated 12 VDC power with a nominal 2.3mA current when the digital input switch is closed 0-20 Hz, 25 msec minimum width

Devices supported: Any device with isolated open drain, open collector, transistor or reed switch

Types: Contacting Flowmeter, Flow Verify

High Speed Counter-Type Digital Inputs

Electrical: Optically isolated and providing an electrically isolated 12 VDC power with a nominal 2.3mA current when the digital input switch is closed, 0-500 Hz, 1.00 msec minimum width

Devices supported: Any device with isolated open drain, open collector, transistor or reed switch

Types: Paddlewheel Flowmeter

4. **Outputs:**

*Powered mechanical relays (0 to 8 depending on model code):*

Pre-powered on circuit board switching line voltage

6 A (resistive), 1/8 HP (93 W)

Two, three or four relays are fused together (depending on model code) as one group, total current for this group must not exceed 6A (resistive), 1/8 HP (93 W)

*Dry contact mechanical relays (0 to 8 depending on model code):*

6 A (resistive), 1/8 HP (93 W)

Dry contact relays are not fuse protected

*Pulse Outputs (0, 2 or 4 depending on model code):*

Opto-isolated, Solid State Relay  
200mA, 40 VDC Max.  
VLOWMAX = 0.05V @ 18 mA

*4 - 20 mA (0 to 16 depending on model code):*

Internally powered, 15 VDC, Fully isolated  
600 Ohm max resistive load  
Resolution 0.0015% of span  
Accuracy ± 0.5% of reading

## 5. Ethernet:

10/100 802.3-2005  
Auto MDIX support  
Auto Negotiation

## 6. Wi-Fi

Radio Protocol: IEEE 802.11 b/g/n Security Protocols  
(Ad-Hoc Mode): WPA2-Personal Security Protocols  
(Infrastructure Mode): WPA/WPA2-Personal, WEP  
Certifications and Compliance: FCC, IC TELEC,  
CE/ETSI, RoHS, Wi-Fi Certified

## 7. Software features:

Eight relay outputs may be set to a variety of control modes:

- » On/Off set point control
- » Time Proportional control
- » Pulse Proportional control (when purchased with solid state opto outputs)
- » Flow Proportional
- » Dual set point
- » Bleed or Feed based on a Water Contactor or Paddlewheel flow meter input
- » Feed and Bleed
- » Feed and Bleed with Lockout
- » Feed as a percent of Bleed
- » Feed as a percent of elapsed time
- » Daily, Weekly, 2-week or 4-week Biocide timers with pre-bleed and post-add lockout of bleed
- » Intermittent sampling for boilers with proportional blowdown, controlling on a trapped sample
- » Always on unless interlocked
- » Probe Wash timer
- » Spike to alternate set point on timed basis
- » Target PPM
- » Flow Meter Ratio
- » Volumetric Blending
- » Disturbance Variable Control
- » PPM Volume
- » Lead/Lag Control
- » Diagnostic Alarm triggered by:
  - High or Low sensor reading
  - No Flow
  - Relay output timeout
  - Sensor error

Eight Virtual Inputs are configurable in the software, to either allow for calculations based on two real inputs, or to allow to compare values from two sensors to provide redundancy, or to be used as a disturbance variable.

Eight Virtual Outputs are configurable in the software, using most of the possible relay or analog output control algorithms, that may be used to interlock or activate actual control outputs.

Manual activation of the relays shall be easily accomplished via the touchscreen, or a PC.

A maximum output on-time shall be available on the control relays to prevent runaway control.

Any relay may be reconfigured to any one of a number of control algorithms, responding to the signal from any input desired.

The optional analog inputs shall be configurable for fluorometers, level sensors, flowmeters, or any other type of transmitter, providing appropriate units of measure and scaling.

The digital inputs shall be configurable for level switches, flowmeters, flow switches, chemical feed monitors or generic interlock operation.

The optional analog outputs shall be configurable for retransmitting a sensor signal, for proportional control, for PID control, for flow proportional control, or for lead/lag control.

The controller set points may be entered by downloading them from one controller, and uploading them into another controller.

Access to the controller shall be possible using Ethernet, locally or via the Internet, Wi-Fi, or via the local touchscreen display, simultaneously if desired.

The standard Ethernet feature provides remote access to the controller's programming via a PC connected directly, via a local area network, or via Walchem's VTouch account management server. It also allows emailing of datalog files (in CSV format, compatible with spreadsheets like Excel) and alarms, to up to eight email addresses. The Modbus TCP and BACnet remote communications options allow communication with PC-based applications, HMI/SCADA programs, Building Energy Management systems, Distributed Control Systems (DCS), as well as stand-alone HMI devices.

No proprietary software shall be required on the user's computer to communicate with the controller, or to view or change set points.

## **C. Sensors:**

### **Contacting Conductivity**

1. Operating principle: The conductivity sensor shall be driven with a low voltage AC signal, and the return signal voltage will vary with the conductivity of the intervening solution. The temperature sensor within this sensor compensates for the effect of temperature on the conductivity signal.
2. Materials of construction: Glass-Filled Polypropylene, Graphite or 316SS, FKM
3. Process connections: 3/4" NPTF
4. Temperature range: 32-158 F, 0-70 C
5. Pressure range: 0-150 psi
6. Other materials and higher pressure sensors shall be made available.

### **Electrodeless Conductivity**

1. Operating principle: The conductivity sensor shall be driven with a low voltage AC signal, which induces a current in the surrounding liquid which varies in intensity with the conductivity of the liquid, which is picked up by the sensor and transmitted to the controller. The temperature sensor within this sensor compensates for the effect of temperature on the conductivity signal.
2. Materials of construction: CPVC, FKM
3. Process connections: 3/4" NPTF
4. Temperature range: 32-158 F, 0-70 C
7. Pressure range: 0-150 psi

### **pH**

1. Operating principle: The pH sensor shall consist of a replaceable cartridge containing a pH sensitive glass and silver/silver chloride reference. Voltage signals from these shall be measured against the solution ground, and the differential voltage measurement sent to the control module. The temperature signal from the conductivity sensor shall be used to compensate the pH reading as well.
2. Materials of construction: Glass-Filled Polypropylene, CPVC, HDPE, FKM, Glass
3. Process connections: 3/4" NPTF
4. Temperature range: 50-158 F, 10-70 C
5. Pressure range: 0-100 psi
6. Other materials and higher pressure sensors shall be made available.

### **ORP**

1. Operating principle: The ORP sensor shall consist of a replaceable cartridge containing a platinum electrode and silver/silver chloride reference. Voltage signals from these shall be measured against the solution ground, and the differential voltage measurement sent to the control module.
2. Materials of construction: Glass-Filled Polypropylene, CPVC, HDPE, FKM, Glass, and Platinum.
3. Process connections: 3/4" NPTF
4. Temperature range: 32-158 F, 0-70 C
5. Pressure range: 0-100 psi
6. Other materials and higher pressure sensors shall be made available.

## **DISINFECTION**

1. Operating principle: The oxidizer molecules diffuse through the membrane and in the acidic environment of the electrolyte fill solution, a redox reaction occurs at the electrodes in the sensor. The current generated by this reaction is converted to a robust voltage signal that is linear with the concentration of the oxidizer.
2. Materials of construction: Glass-Filled Polypropylene, PVC, Silicone rubber, polycarbonate, 316SS, PEEK.
3. Process connections: 3/4" NPTF
4. Temperature range: 41-113 F, 5-45 C (typical)
5. Pressure range: 0-14.7 psi (0-1 atmosphere)

## D. Controller and Sensor Performance

### 0.01 Cell Contacting Conductivity

Range	0-300 $\mu\text{S/cm}$
Resolution	0.01 $\mu\text{S/cm}$ , 0.0001 mS/cm, 0.001 mS/m, 0.0001 S/m, 0.01 ppm
Accuracy	$\pm 1\%$ of reading

### 0.1 Cell Contacting Conductivity

Range	0-3,000 $\mu\text{S/cm}$
Resolution	0.1 $\mu\text{S/cm}$ , 0.0001 mS/cm, 0.01 mS/m, 0.0001 S/m, 0.1 ppm
Accuracy	$\pm 1\%$ of reading

### 1.0 Cell Contacting Conductivity

Range	0-30,000 $\mu\text{S/cm}$
Resolution	1 $\mu\text{S/cm}$ , 0.001 mS/cm, 0.1 mS/m, 0.0001 S/m, 1 ppm
Accuracy	$\pm 1\%$ of reading

### 10.0 Cell Contacting Conductivity

Range	0-300,000 $\mu\text{S/cm}$
Resolution	10 $\mu\text{S/cm}$ , 0.01 mS/cm, 1 mS/m, 0.001 S/m, 10 ppm
Accuracy	$\pm 1\%$ of reading

### Corrosion

Range	Resolution
0-2 mpy or mm/year	0.001 mpy or mm/year
0-20 mpy or mm/year	0.01 mpy or mm/year
0-200 mpy or mm/year	0.1 mpy or mm/year

### pH

Range	-2 to 16 pH units
Resolution	0.01 pH units
Accuracy	$\pm 0.01\%$ of reading

### ORP/ISE

Range	-1500 to 1500 mV
Resolution	0.1 mV
Accuracy	$\pm 1$ mV

### Disinfection Sensors

Range (mV)	-2000 to 1500 mV	Range (ppm)	0-2 ppm to 0-20,000 ppm
Resolution (mV)	0.1 mV	Resolution (ppm)	Varies with range and slope
Accuracy (mV)	$\pm 1$ mV	Accuracy (ppm)	Varies with range and slope

### Temperature

Range	23 to 500°F (-5 to 260°C)
Resolution	0.1°F (0.1°C)
Accuracy	$\pm 1\%$ of reading

### Analog (4-20 mA)

Range	0 to 22 mA
Resolution	0.01 mA
Accuracy	$\pm 0.5\%$ of reading

### Electrodeless Conductivity

Ranges	Resolution	Accuracy
500-12,000 $\mu\text{S/cm}$	1 $\mu\text{S/cm}$ , 0.01 mS/cm, 0.1 mS/m, 0.001 S/m, 1 ppm	$\pm 1\%$ of reading
3,000-40,000 $\mu\text{S/cm}$	1 $\mu\text{S/cm}$ , 0.01 mS/cm, 0.1 mS/m, 0.001 S/m, 1 ppm	$\pm 1\%$ of reading
10,000-150,000 $\mu\text{S/cm}$	10 $\mu\text{S/cm}$ , 0.1 mS/cm, 1 mS/m, 0.01 S/m, 10 ppm	$\pm 1\%$ of reading
50,000-500,000 $\mu\text{S/cm}$	10 $\mu\text{S/cm}$ , 0.1 mS/cm, 1 mS/m, 0.01 S/m, 10 ppm	$\pm 1\%$ of reading
200,000-2,000,000 $\mu\text{S/cm}$	100 $\mu\text{S/cm}$ , 0.1 mS/cm, 1 mS/m, 0.1 S/m, 100 ppm	$\pm 1\%$ of reading

## E. Indication

### 1. Graphic User Interface

A 320 x 240 pixel monochrome backlit display with touchscreen shall indicate the process values, the status of outputs and alarms, and provide for all settings and calibrations.

Eight LED lamps shall indicate the on/off status of the control outputs.

## **F. Equipment**

The cooling tower controller shall be a Walchem WCT900 series.

### **Part 3. Operator Functions**

#### **3.1 Calibration**

- A.** The sensor calibration shall be a one point process calibration, a two point buffer calibration, or a one point buffer calibration.
- B.** All set points shall be set through the touchscreen, or via a PC connected either locally or remotely via Ethernet or Wi-Fi.
- C.** Two levels of access codes shall be available to protect all set points and calibrations, while allowing the user to view any set point.

#### **3.2 Control Module Function Details**

- A.** Each control output shall be able to be set to any of the available control modes listed above.
- B.** The inhibitor chemical feed output shall be on/off control with four choices of feed modes.
- C.** All control relays shall have limit timers to prevent runaway control.
- D.** The biocide programs shall provide a conductivity-based or a time-based prebleed prior to the biocide addition, and a time-based lockout of the bleed after the biocide addition.
- E.** The controller shall be able to interlock any relay output based on a digital input or based on another specific relay being active.

### **Part 4. Execution**

#### **4.1 Installation**

- A.** The sensors shall be installed in a location where they will always remain immersed in the sample.
- A.** The sensors shall be installed in a location where there is good solution movement and where they will respond rapidly to changes



- B. The sensor cables shall be routed such that they are separated from any AC voltage by at least 6 inches.
- C. If the sensor cable needs to be extended beyond the standard length, then 24 AWG, 3 twisted pair, shielded cable shall be utilized.
- E. If the optional 4 – 20 mA output or water meter contactor are installed, then 22-26 AWG, twisted pair, shielded cable shall be utilized.
- F. The sample line shall be tapped from the discharge side of the cooling tower recirculation pump and returned to either the cooling tower sump or the suction side of the recirculation pump.

## **Part 5. Warranty**

### **5.1 Terms**

- A. The manufacturer of the above specified equipment shall guarantee equipment of its manufacture, and bearing its identification to be free from defects in workmanship and material for a period of 24 months for electronics and 12 months for mechanical parts from date of delivery from the factory or authorized distributor under normal use and service and otherwise when such equipment is used in accordance with instructions furnished by the manufacturer and for the purposes disclosed in writing at the time of purchase, if any.
- B. In the event a component fails to perform as specified and having been returned to the manufacturer transportation charges prepaid, and is proven defective in service during the warranty period, the manufacturer shall repair or replace the defective part. Replaceable elastomeric parts and glass components are expendable and are not covered by any warranty.

## **Part 6. Options**

### **6.1 Related Equipment**

- A. Solenoid valve for bleed control
- B. Water meter for makeup and/or bleed flow
- C. Level switch or level transmitter for chemical level monitoring
- D. Metering pumps for chemical control

## **Part 7. Spare Parts**

### **7.1 Recommended Spare Parts**

- A. 102834 Fuse, F1, 6 amp 250 V, 5 x 20 mm

**Part 8.      Dimensions (inches)**

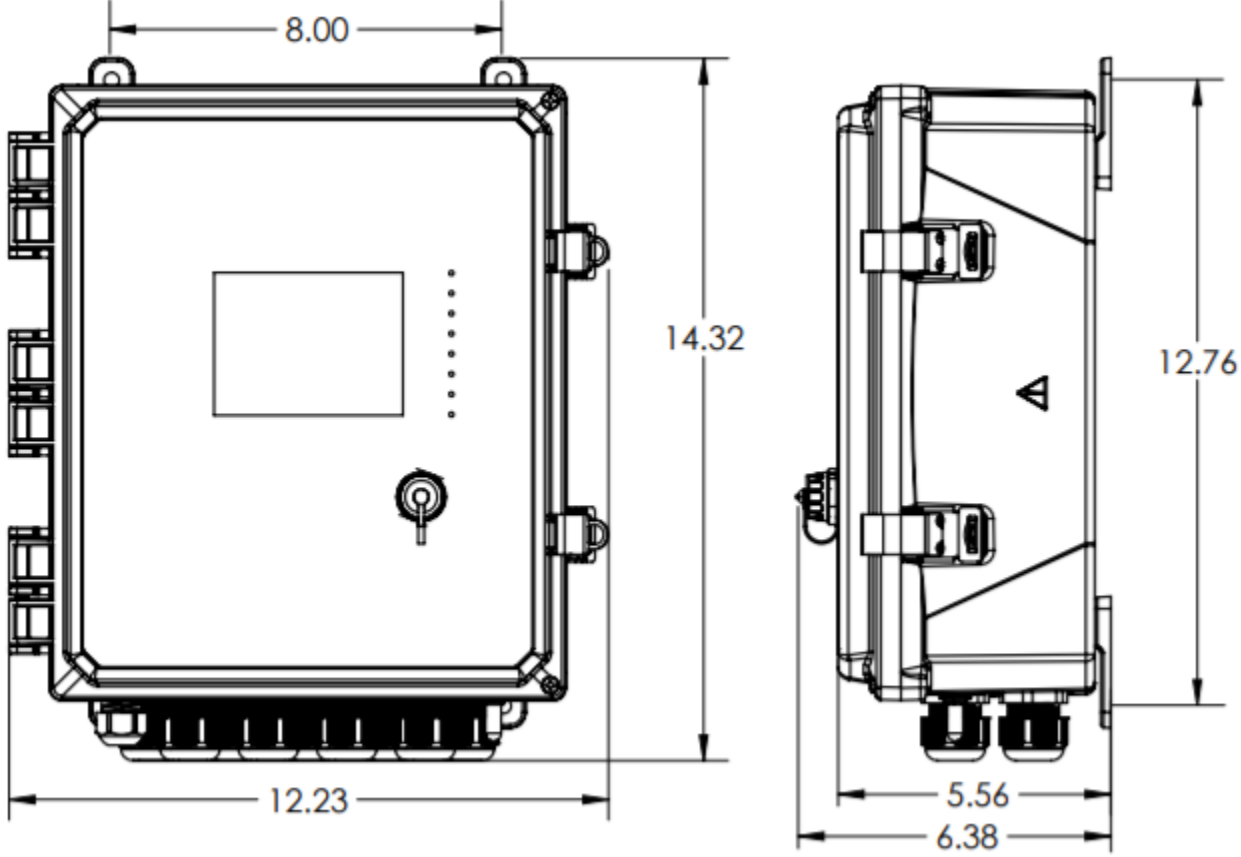

**Part 9. Wiring**

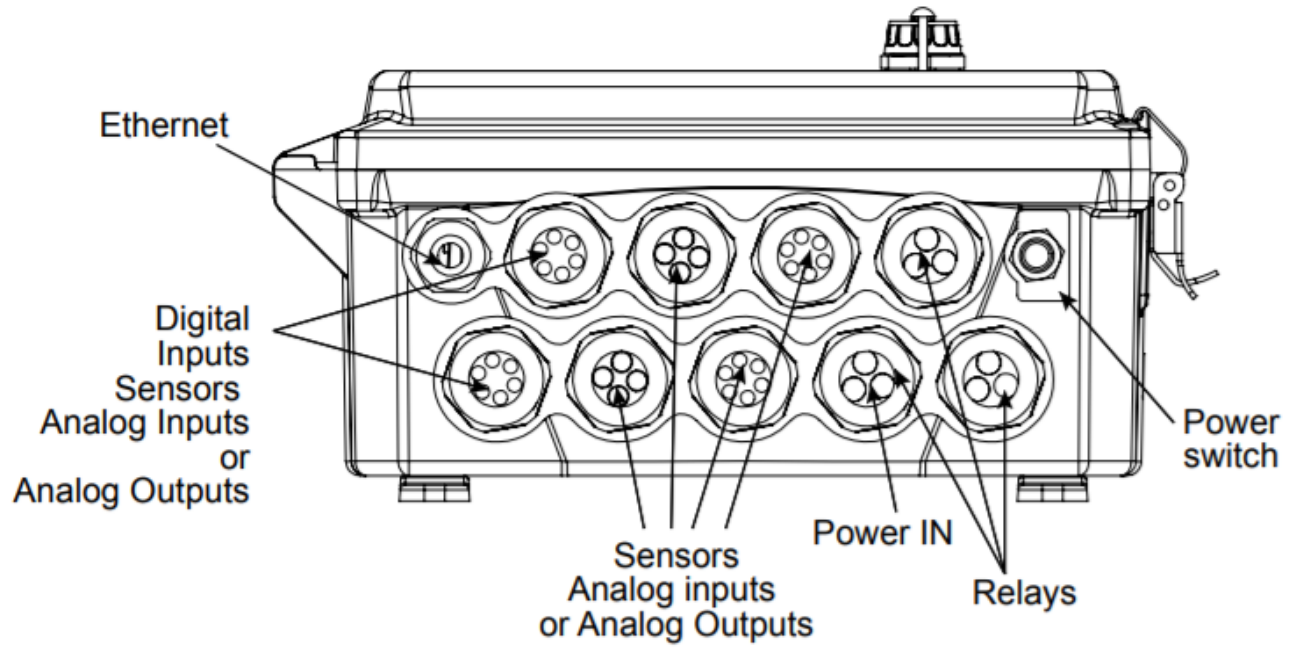

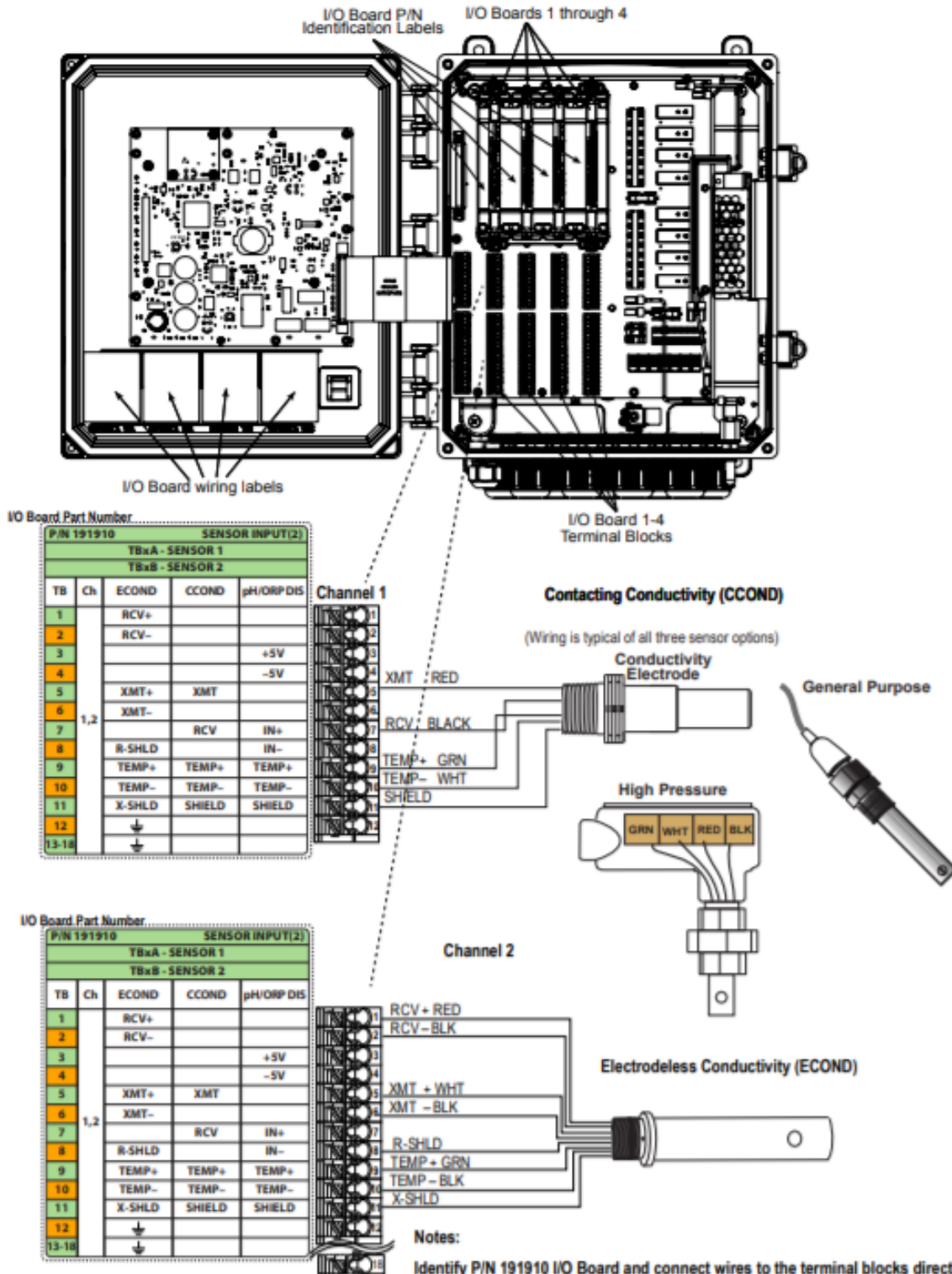

### Conductivity Sensor Input Wiring

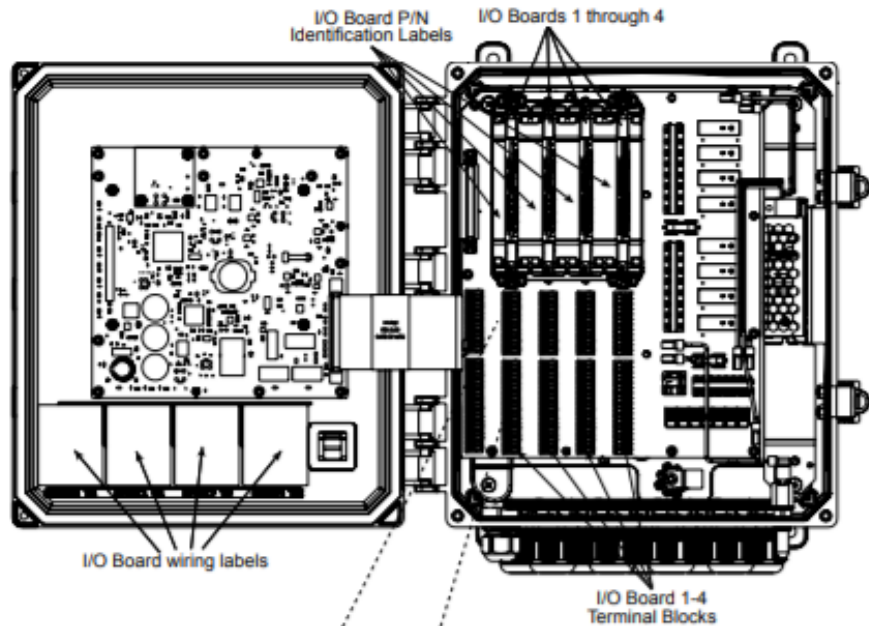

I/O Board Part Number

P/N 191910		SENSOR INPUT(2)			
		TBxA - SENSOR 1		TBxB - SENSOR 2	
TB	Ch	ECOND	CCOND	pH/ORP DIS	
1		RCV+			
2		RCV-			
3				+5V	
4				-5V	
5		XMT+	XMT		
6	1,2	XMT-			
7			RCV	IN+	
8		R-SHLD		IN-	
9		TEMP+	TEMP+	TEMP+	
10		TEMP-	TEMP-	TEMP-	
11		X-SHLD	SHIELD	SHIELD	
12					
13-14					

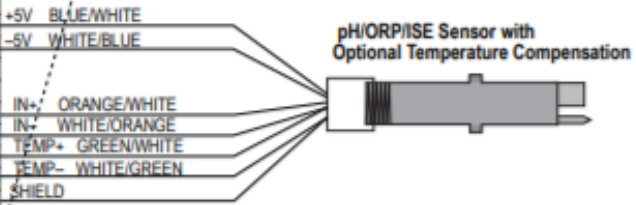

**Notes:**

Identify P/N 191910 I/O Board and connect wires to the terminal blocks directly below the I/O slot that the board is in.

Use the wiring label located on the front panel that has a matching I/O part number.

Either channel can support any of the sensor types listed.

I/O Board Part Number

P/N 191910		SENSOR INPUT(2)			
		TBxA - SENSOR 1		TBxB - SENSOR 2	
TB	Ch	ECOND	CCOND	pH/ORP DIS	
1		RCV+			
2		RCV-			
3				+5V	
4				-5V	
5		XMT+	XMT		
6	1,2	XMT-			
7			RCV	IN+	
8		R-SHLD		IN-	
9		TEMP+	TEMP+	TEMP+	
10		TEMP-	TEMP-	TEMP-	
11		X-SHLD	SHIELD	SHIELD	
12					
13-14					

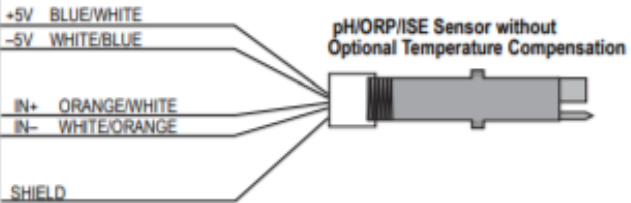

**pH/ORP/ISE Sensor Input Wiring**

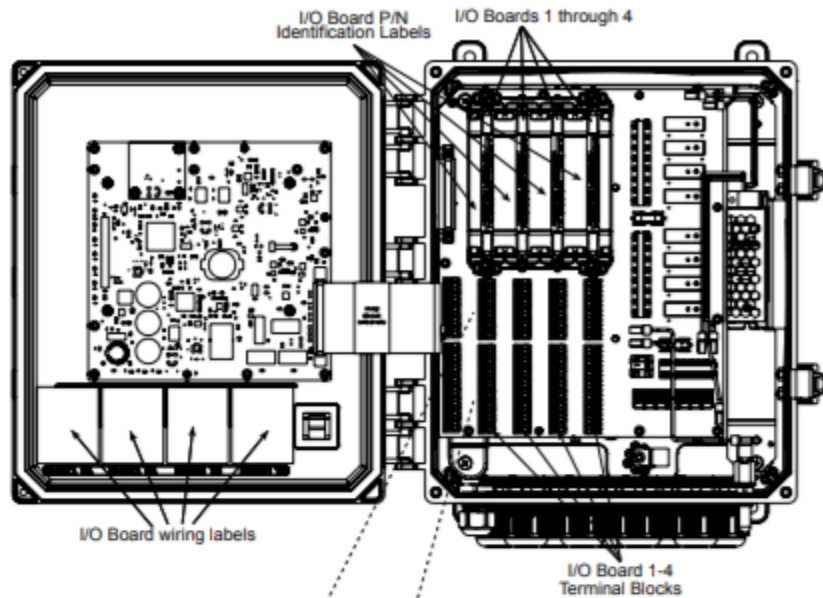

**I/O Board Part Number**

P/N 191910		SENSOR INPUT(2)		
		TBxA - SENSOR 1		
		TBxB - SENSOR 2		
TB	Ch	ECOND	CCOND	pH/ORP/DIS
1		RCV+		
2		RCV-		
3				+5V
4				-5V
5		XMT+	XMT	
6		XMT-		
7	1,2		RCV	IN+
8		R-SHLD		IN-
9		TEMP+	TEMP+	TEMP+
10		TEMP-	TEMP-	TEMP-
11		X-SHLD	SHIELD	SHIELD
12				
13-18				

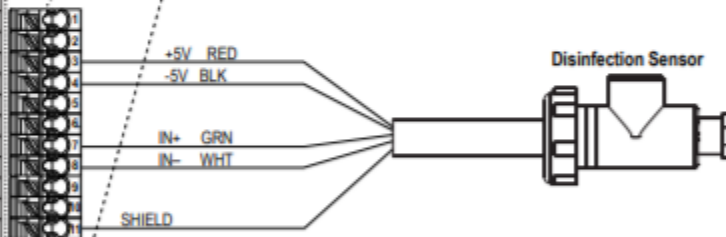

**Notes:**

Identify P/N 191910 I/O Board and connect wires to the terminal blocks directly below the I/O slot that the board is in.

Use the wiring label located on the front panel that has a matching I/O part number.

Either channel can support any of the sensor types listed.

**I/O Board Part Number**

P/N 191910		SENSOR INPUT(2)		
		TBxA - SENSOR 1		
		TBxB - SENSOR 2		
TB	Ch	ECOND	CCOND	pH/ORP/DIS
1		RCV+		
2		RCV-		
3				+5V
4				-5V
5		XMT+	XMT	
6		XMT-		
7	1,2		RCV	IN+
8		R-SHLD		IN-
9		TEMP+	TEMP+	TEMP+
10		TEMP-	TEMP-	TEMP-
11		X-SHLD	SHIELD	SHIELD
12				
13-18				

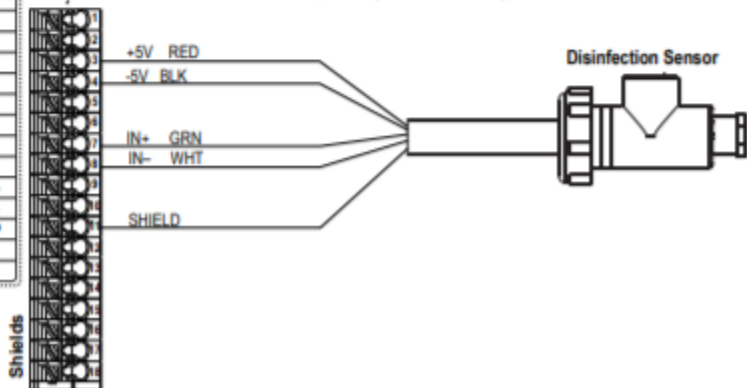

**Disinfection Sensor Input Wiring**

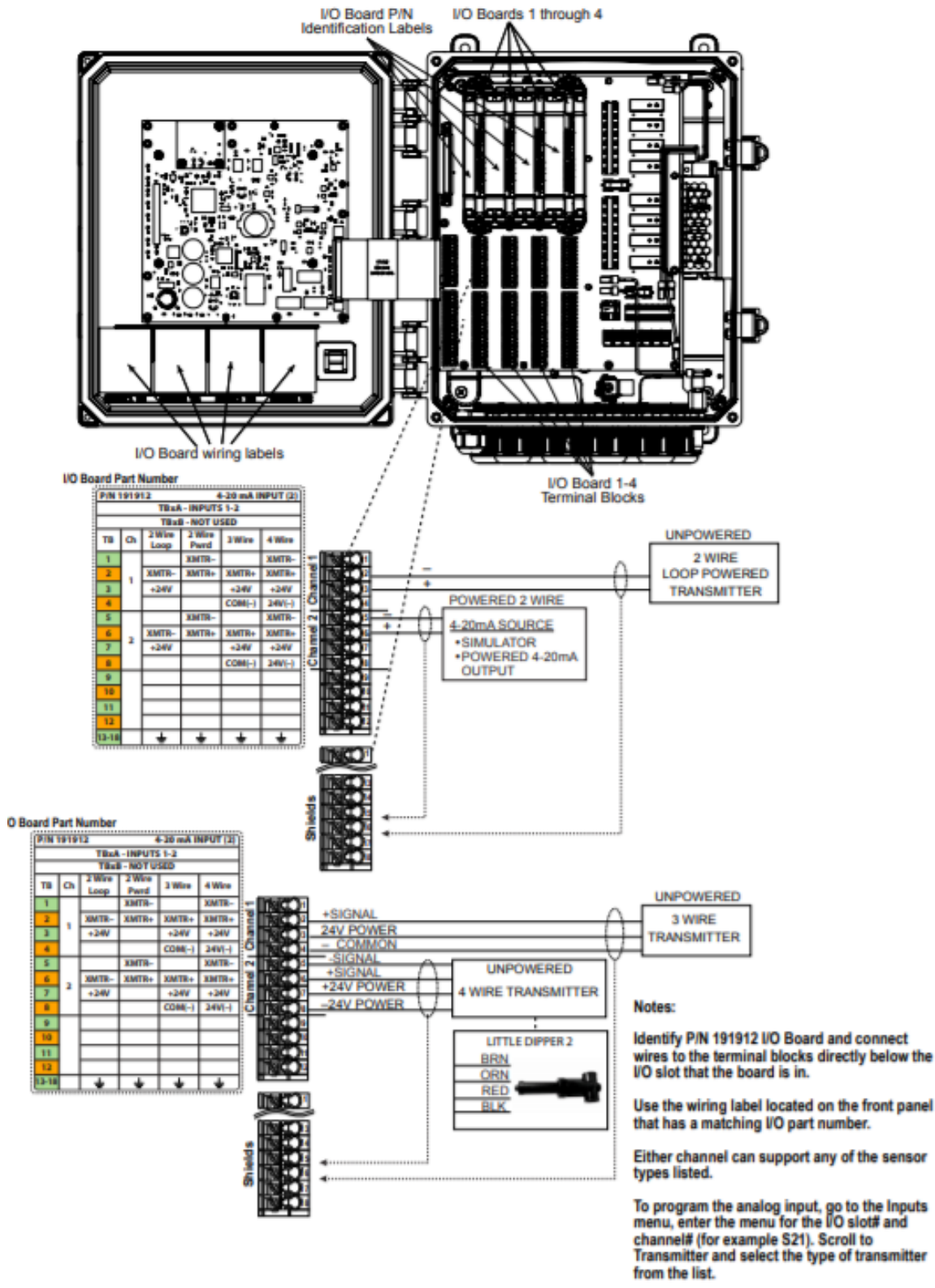

Dual 4-20mA Sensor Input Card Wiring

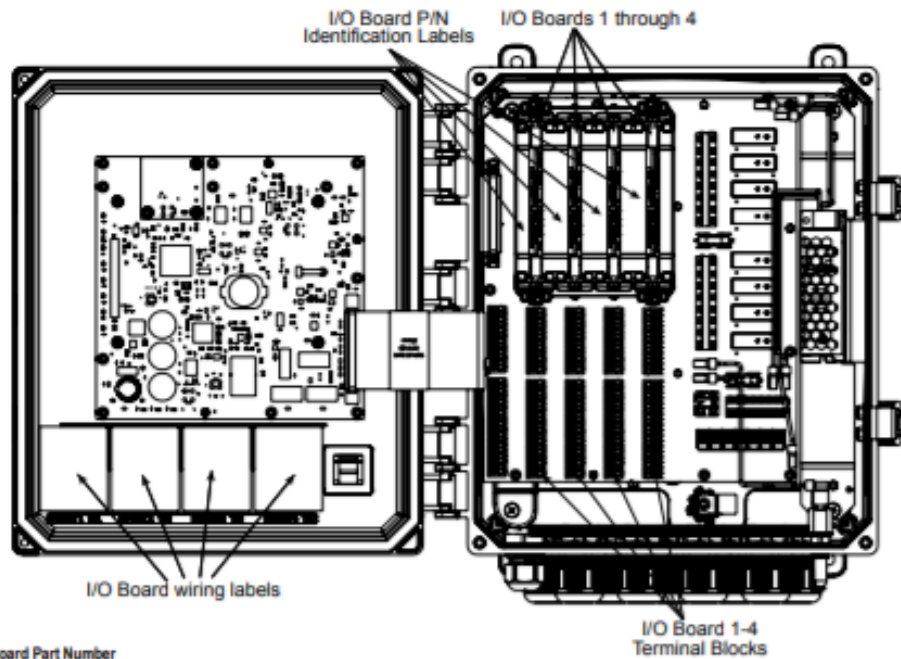

I/O Board Part Number

P/N 191913		4-20 mA INPUT (4)			
TBaA - INPUTS 1-3		TBaB - INPUT 4			
TB	Ch	2 Wire Loop	2 Wire Pwrd	3 Wire	4 Wire
1			XMTB-		XMTB-
2	1,4	XMTB-	XMTB+	XMTB-	XMTB+
3		+24V		+24V	+24V
4				COM(-)	24V(-)
5			XMTB-		XMTB-
6	2	XMTB-	XMTB+	XMTB-	XMTB+
7		+24V		+24V	+24V
8				COM(-)	24V(-)
9			XMTB-		XMTB-
10	3	XMTB-	XMTB+	XMTB-	XMTB+
11		+24V		+24V	+24V
12				COM(-)	24V(-)
13-18					

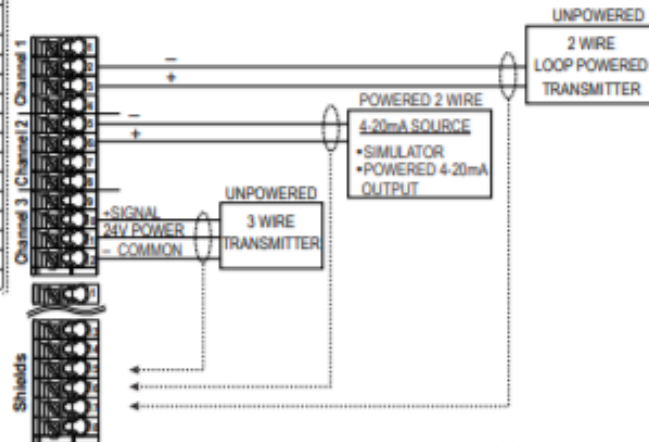

I/O Board Part Number

P/N 191913		4-20 mA INPUT (4)			
TBaA - INPUTS 1-3		TBaB - INPUT 4			
TB	Ch	2 Wire Loop	2 Wire Pwrd	3 Wire	4 Wire
1			XMTB-		XMTB-
2	1,4	XMTB-	XMTB+	XMTB-	XMTB+
3		+24V		+24V	+24V
4				COM(-)	24V(-)
5			XMTB-		XMTB-
6	2	XMTB-	XMTB+	XMTB-	XMTB+
7		+24V		+24V	+24V
8				COM(-)	24V(-)
9			XMTB-		XMTB-
10	3	XMTB-	XMTB+	XMTB-	XMTB+
11		+24V		+24V	+24V
12				COM(-)	24V(-)
13-18					

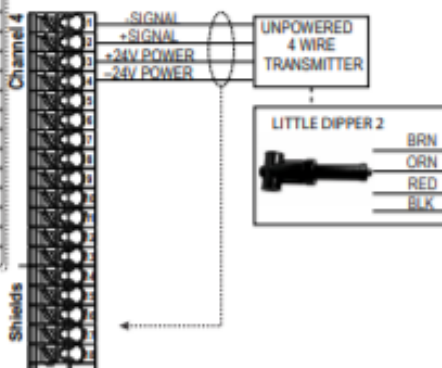

**Notes:**

Identify P/N 191913 I/O Board and connect wires to the terminal blocks directly below the I/O slot that the board is in.

Use the wiring label located on the front panel that has a matching I/O part number.

Either channel can support any of the sensor types listed.

To program the analog input, go to the Inputs menu, enter the menu for the I/O slot# and channel# (for example S21). Scroll to Transmitter and select the type of transmitter from the list.

**Four 4-20mA Sensor Input Card Wiring**



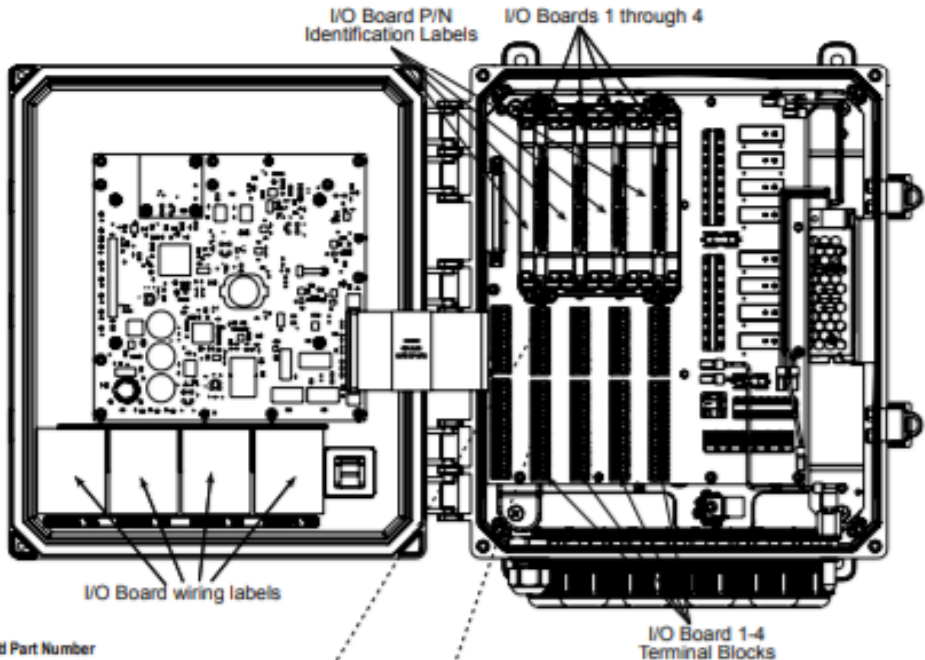

I/O Board Part Number

P/N 191914 4-20 mA INPUT (6)					
TBxA - INPUTS 1-3			TBxB - INPUTS 4-6		
TB	Ch	2 Wire Loop	2 Wire Paralle	3 Wire	4 Wire
1			XMTR-	XMTR-	XMTR-
2			XMTR+	XMTR+	XMTR+
3	1,4	+24V		+24V	+24V
4				COM(-)	24V(-)
5			XMTR-	XMTR-	XMTR-
6			XMTR+	XMTR+	XMTR+
7	2,5	+24V		+24V	+24V
8				COM(-)	24V(-)
9			XMTR-	XMTR-	XMTR-
10			XMTR+	XMTR+	XMTR+
11	3,6	+24V		+24V	+24V
12				COM(-)	24V(-)
13-18					

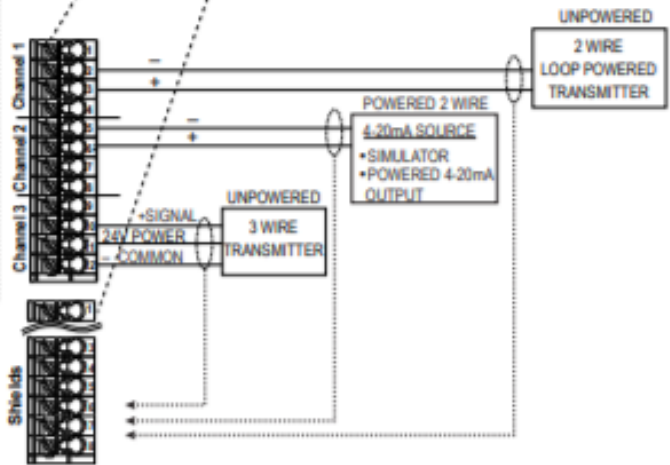

I/O Board Part Number

P/N 191914 4-20 mA INPUT (6)					
TBxA - INPUTS 1-3			TBxB - INPUTS 4-6		
TB	Ch	2 Wire Loop	2 Wire Paralle	3 Wire	4 Wire
1			XMTR-	XMTR-	XMTR-
2			XMTR+	XMTR+	XMTR+
3	1,4	+24V		+24V	+24V
4				COM(-)	24V(-)
5			XMTR-	XMTR-	XMTR-
6			XMTR+	XMTR+	XMTR+
7	2,5	+24V		+24V	+24V
8				COM(-)	24V(-)
9			XMTR-	XMTR-	XMTR-
10			XMTR+	XMTR+	XMTR+
11	3,6	+24V		+24V	+24V
12				COM(-)	24V(-)
13-18					

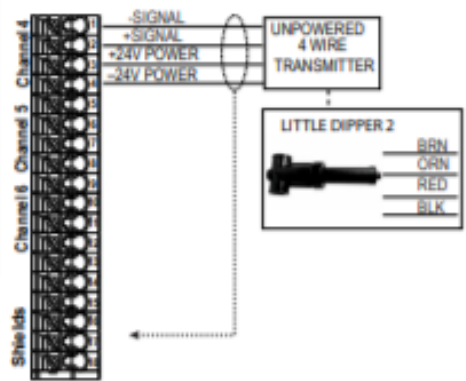

Notes:

Identify P/N 191914 I/O Board and connect wires to the terminal blocks directly below the I/O slot that the board is in.

Use the wiring label located on the front panel that has a matching I/O part number.

Either channel can support any of the sensor types listed.

To program the analog input, go to the Inputs menu, enter the menu for the I/O slot# and channel# (for example S21). Scroll to Transmitter and select the type of transmitter from the list.

Six 4-20mA Sensor Input Card Wiring

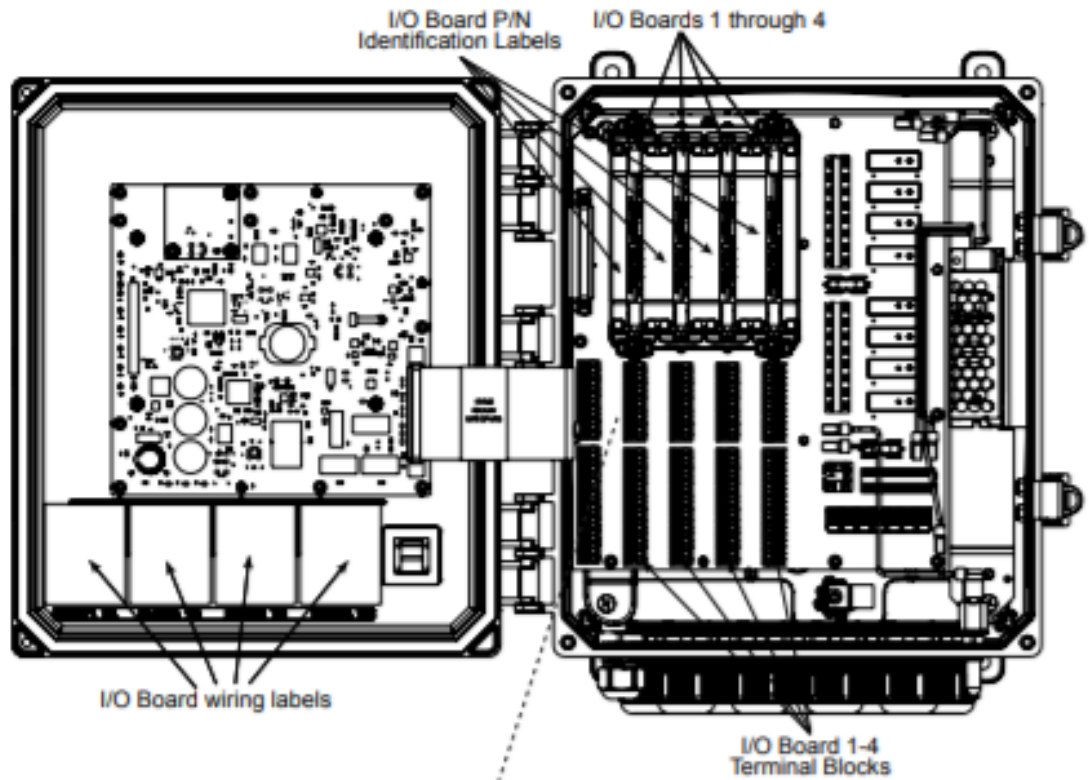

I/O Board Part Number

P/N 191915		4-20 mA OUTPUT (2)	
TBxA - OUTPUTS 1-2			
TBxB - NOT USED			
TB	Ch	4-20 mA Output	
1			
2			
3			
4			
5			
6	Out 1	OUT-	
7		OUT+	
8		⏚	
9	Out 2	OUT-	
10		OUT+	
11		⏚	
12			
13-18		⏚	

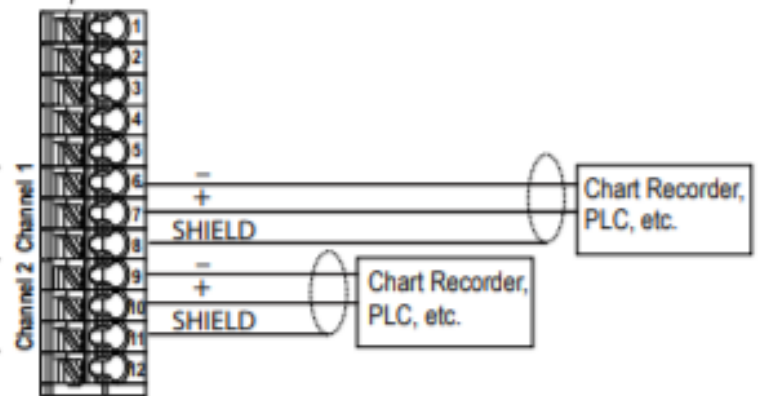

**Notes:**

- Identify P/N 191915 I/O Board and connect wires to the terminal blocks directly below the I/O slot that the board is in.
- Use the wiring label located on the front panel that has a matching I/O part number.
- Either channel can support any of the sensor types listed.
- Each analog output is internally powered, 15 VDC, fully isolated.

**Dual 4-20mA Output Card Wiring**

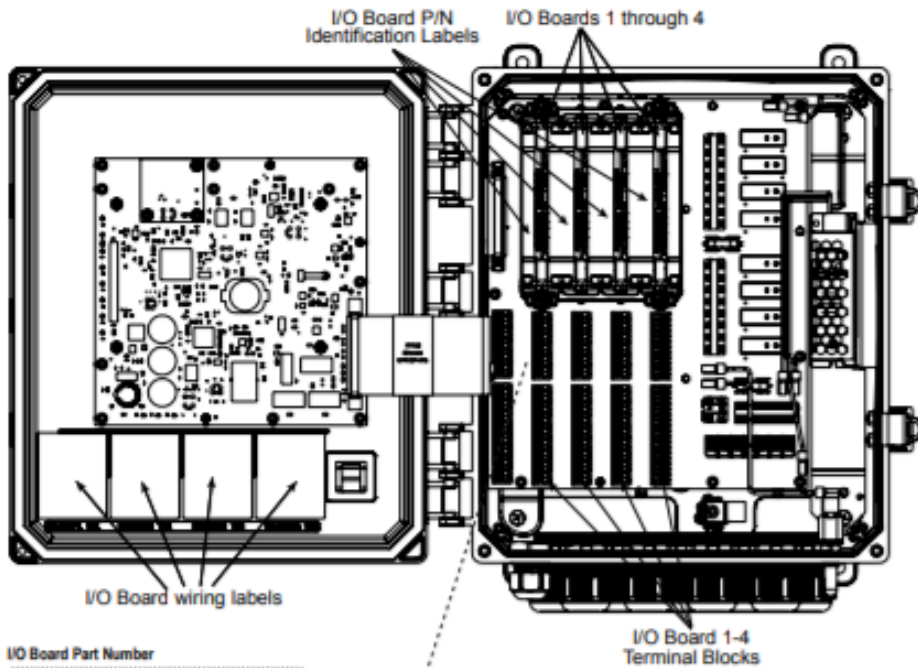

I/O Board Part Number

P/N 191916		4-20 mA OUTPUT (4)
TBxA - OUTPUTS 1-2		
TBxB - OUTPUTS 3-4		
TB	Ch	4-20 mA Output
1		
2		
3		
4		
5		
6		OUT-
7	Out 1,3	OUT+
8		↓
9		OUT-
10	Out 2,4	OUT+
11		↓
12		
13-16		↓

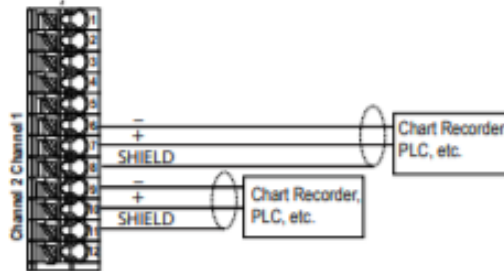

**Notes:**

Identify P/N 191916 I/O Board and connect wires to the terminal blocks directly below the I/O slot that the board is in.

Use the wiring label located on the front panel that has a matching I/O part number.

Either channel can support any of the sensor types listed.

Each analog output is internally powered, 15 VDC, fully isolated.

I/O Board Part Number

P/N 191916		4-20 mA OUTPUT (4)
TBxA - OUTPUTS 1-2		
TBxB - OUTPUTS 3-4		
TB	Ch	4-20 mA Output
1		
2		
3		
4		
5		
6		OUT-
7	Out 1,3	OUT+
8		↓
9		OUT-
10	Out 2,4	OUT+
11		↓
12		
13-16		↓

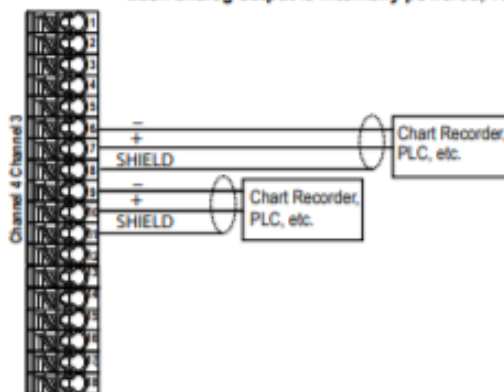

**Four 4-20mA Output Card Wiring**

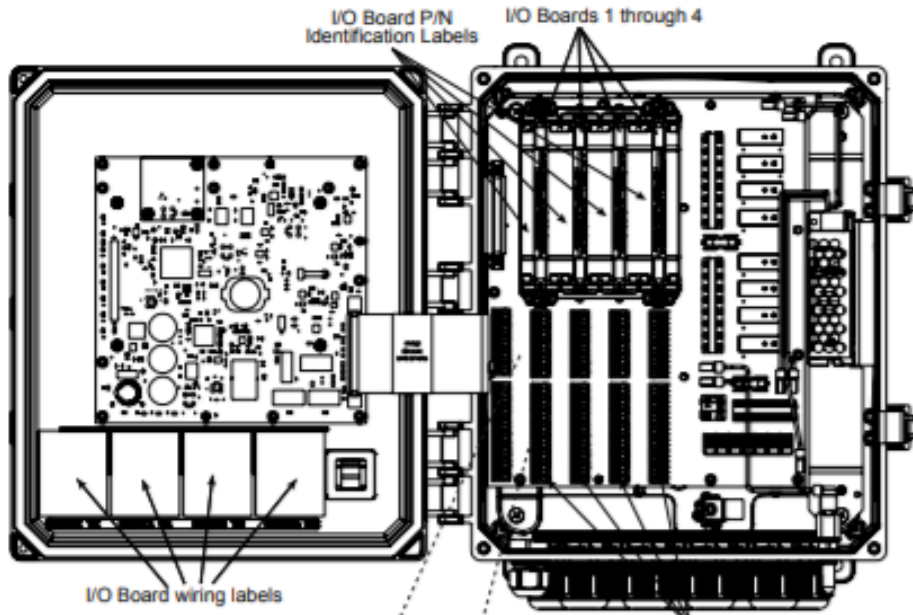

**I/O Board Part Number**

P/N 191918 - 4-20 mA INPUT (1) OUTPUT (4)					
TBxA - INPUT 1, OUTPUTS 1-2					
TBxB - INPUT 2, OUTPUTS 3-4					
TB	Ch	2 Wire Loop	2 Wire Pwr	3 Wire	4 Wire
1				3MTB-	3MTB+
2	In			3MTB-	3MTB+
3	1,2	+24V		+24V	+24V
4				COM-	24V-1
5					
6	Out				OUT-
7	1,3				OUT+
8					
9	Out				OUT-
10	2,4				OUT+
11					
12					
13-18					

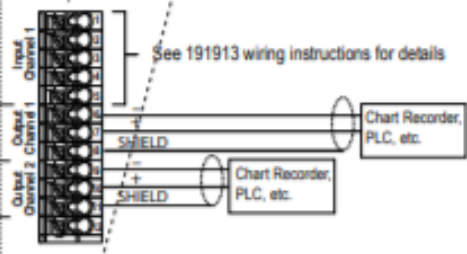

**I/O Board Part Number**

P/N 191918 - 4-20 mA INPUT (2) OUTPUT (4)					
TBxA - INPUT 1, OUTPUTS 1-2					
TBxB - INPUT 2, OUTPUTS 3-4					
TB	Ch	2 Wire Loop	2 Wire Pwr	3 Wire	4 Wire
1				3MTB-	3MTB+
2	In			3MTB-	3MTB+
3	1,2	+24V		+24V	+24V
4				COM-	24V-1
5					
6	Out				OUT-
7	1,3				OUT+
8					
9	Out				OUT-
10	2,4				OUT+
11					
12					
13-18					

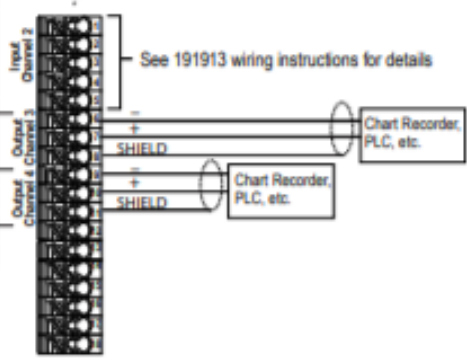

**Notes:**

- Identify P/N 191918 I/O Board and connect wires to the terminal blocks directly below the I/O slot that the board is in.
- Use the wiring label located on the front panel that has a matching I/O part number.
- Either channel can support any of the sensor types listed.
- Each analog output is internally powered, 15 VDC, fully isolated.
- To program the analog input, go to the Inputs menu, enter the menu for the I/O slot# and channel# (for example S21). Scroll to Transmitter and select the type of transmitter from the list.

**Dual Analog (4-20mA) Input + Four Analog (4-20mA) Output Wiring**

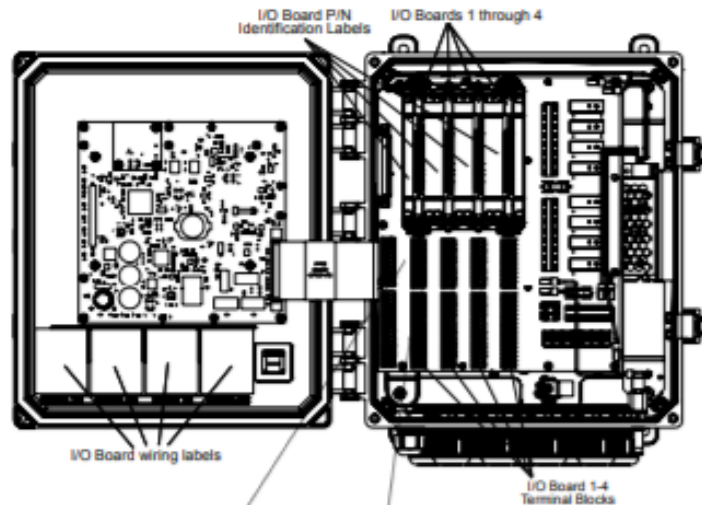

I/O Board Part Number

P/N 191920		CORROSION INPUT(2)
TBxA - SENSOR 1		
TBxB - SENSOR 2		
TB	Ch	CORROSION
1		
2		
3		
4		
5		
6	1,2	XMT (Red)
7		RCV (Green)
8		MON RCV (Black)
9		MON XMT (White)
10		
11		
12		
13-18		SHIELD

Channel 1



XMT RED  
RCV GRN  
MON RCV BLK  
MON XMT WHT

SHIELD

I/O Board Part Number

P/N 191920		CORROSION INPUT(2)
TBxA - SENSOR 1		
TBxB - SENSOR 2		
TB	Ch	CORROSION
1		
2		
3		
4		
5		
6	1,2	XMT (Red)
7		RCV (Green)
8		MON RCV (Black)
9		MON XMT (White)
10		
11		
12		
13-18		SHIELD

Channel 2

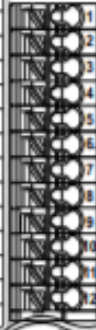

XMT RED  
RCV GRN  
MON RCV BLK  
MON XMT WHT

SHIELD

**Notes:**  
Identify P/N 191920 I/O Board and connect wires to the terminal blocks directly below the I/O slot that the board is in.  
Use the wiring label located on the front panel that has a matching I/O part number.  
Either channel can support any of the sensor types listed.

## Dual Corrosion Sensor Input Board Wiring

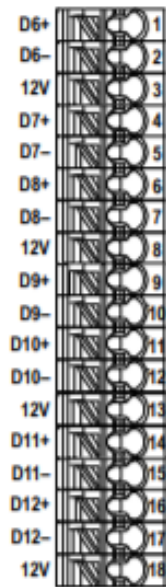
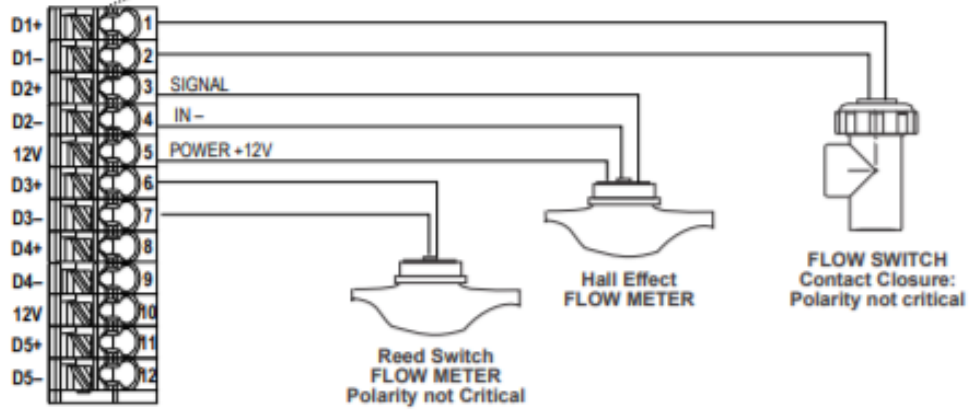
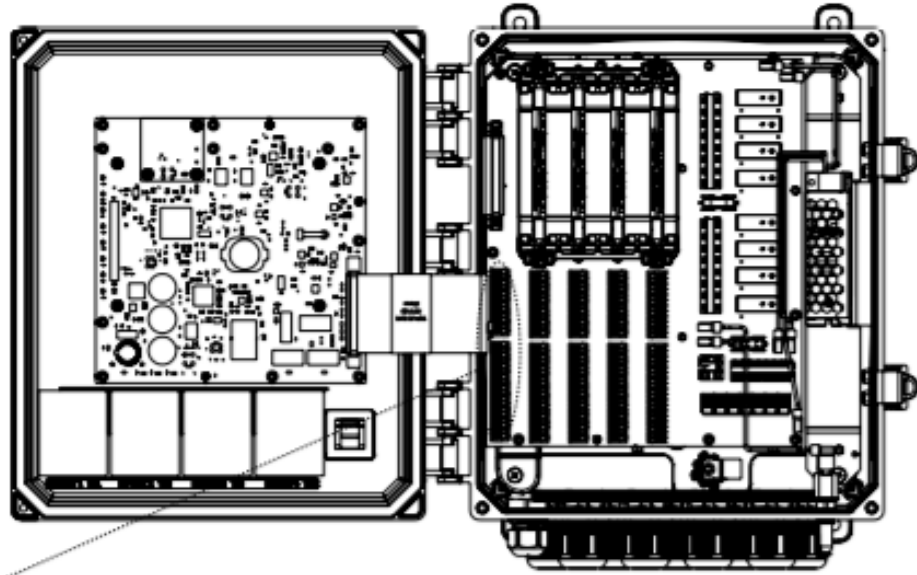

TBDI

### Digital Input Wiring

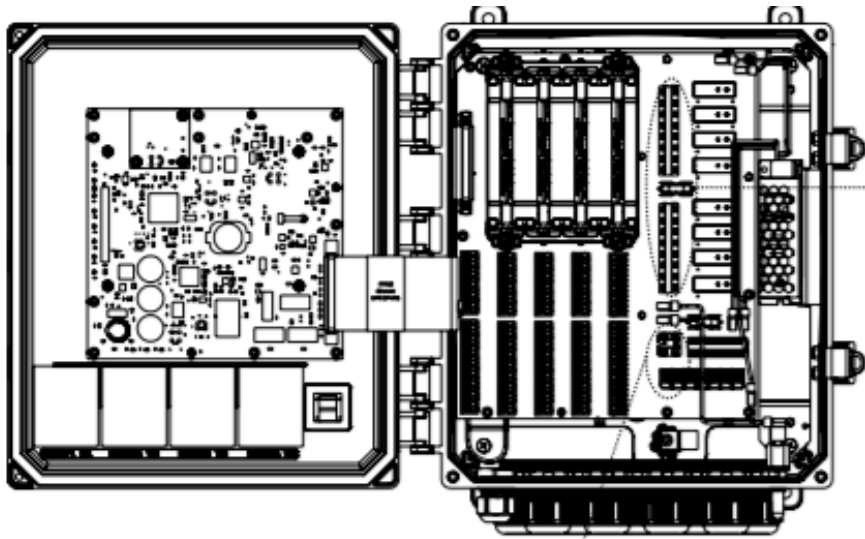

Relay Model Code	R1	R2	R3	R4	R5	R6	R7	R8
900	Powered	Powered	Powered	Powered	Powered	Powered	Powered	Powered
910	Powered	Powered	Powered	Powered	Powered	Powered	Powered	Dry
920	Dry	Dry	Dry	Dry	Dry	Dry	Pulse	Pulse
930	Powered	Powered	Dry	Dry	Powered	Powered	Dry	Dry
940	Dry	Dry	Pulse	Pulse	Dry	Dry	Pulse	Pulse
950	Powered	Powered	Pulse	Pulse	Powered	Powered	Pulse	Pulse
960	Powered	Powered	Powered	Powered	Powered	Powered	Pulse	Pulse
970	Dry	Dry	Dry	Dry	Dry	Dry	Dry	Dry

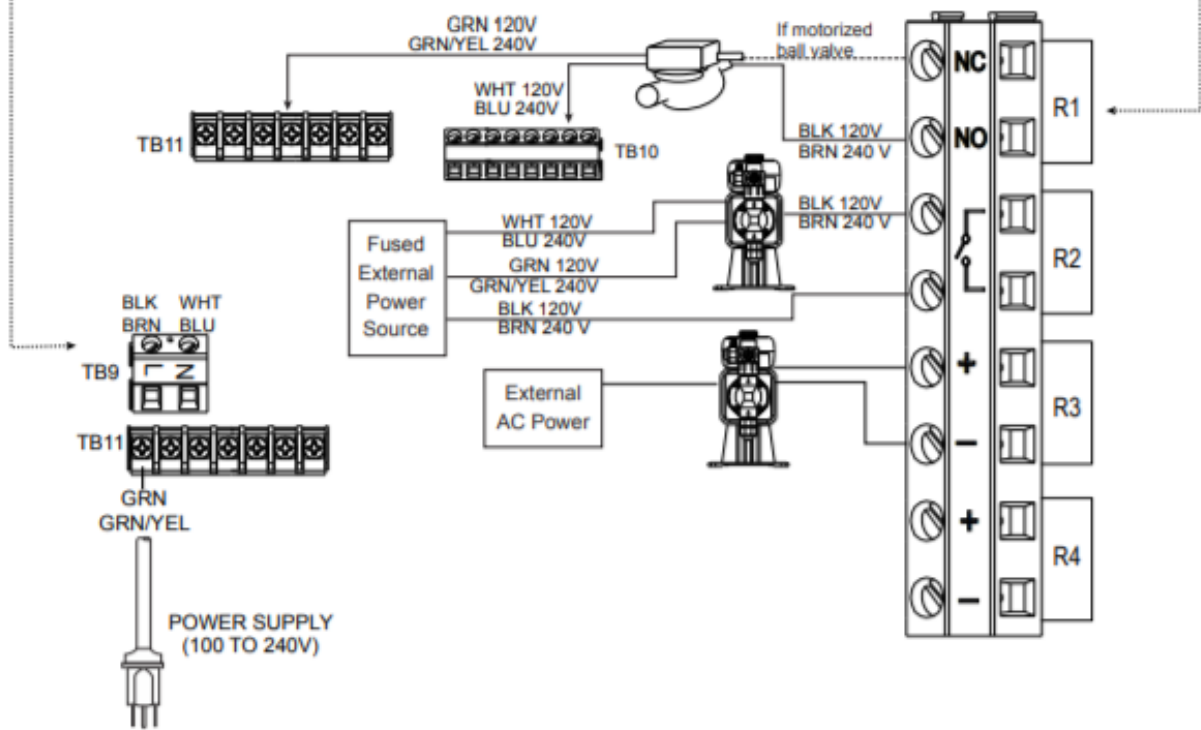

**AC Power & Relay Output Wiring**